

REFERENCES:
 3-VIEW DRAWINGS
 R.S. HIRSCH, 1968
 W.F. KERKA, 1975

COLOR SCHEME:
 FUSELAGE, FIN, RUDDER
 WING, STABILIZER - YELL
 REG., RACE NOS. ON WIN
 RACE NOS. ON FUSELAGE
 REG. NOS. ON FIN/RUDD
 PROP - SILVER, DULL B
 WHEEL COVERS - BLACK

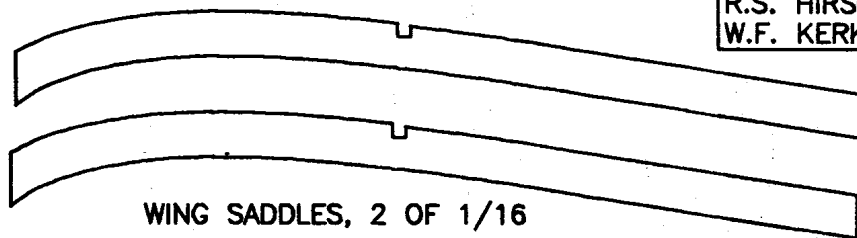

WING SADDLES, 2 OF 1/16

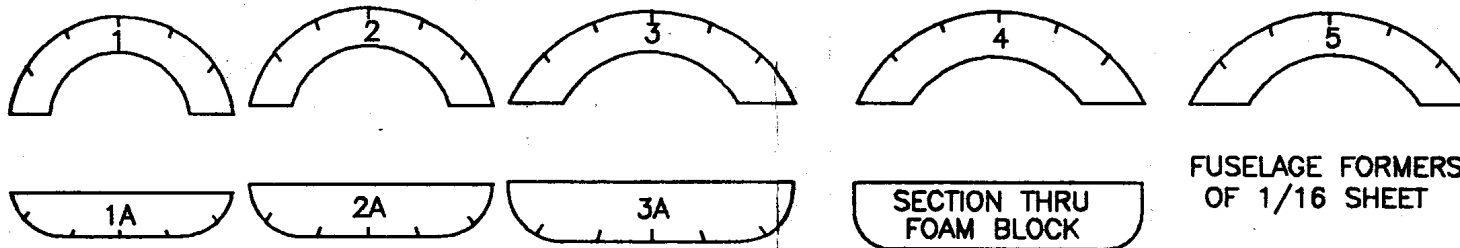

FUSELAGE FORMERS
 OF 1/16 SHEET

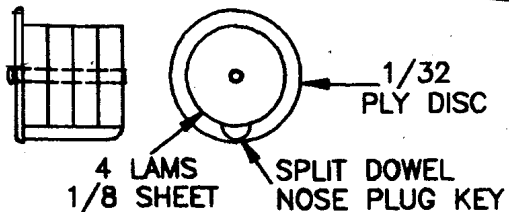
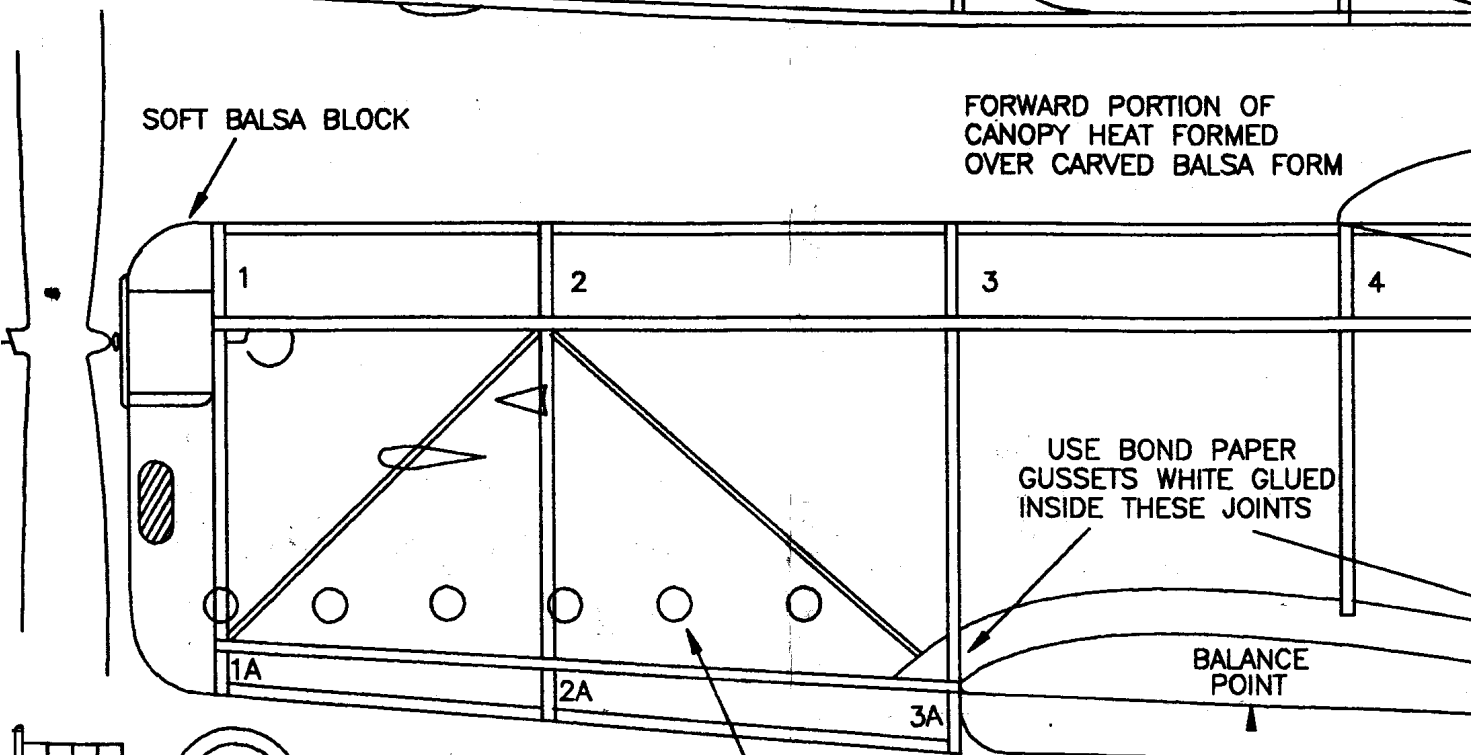
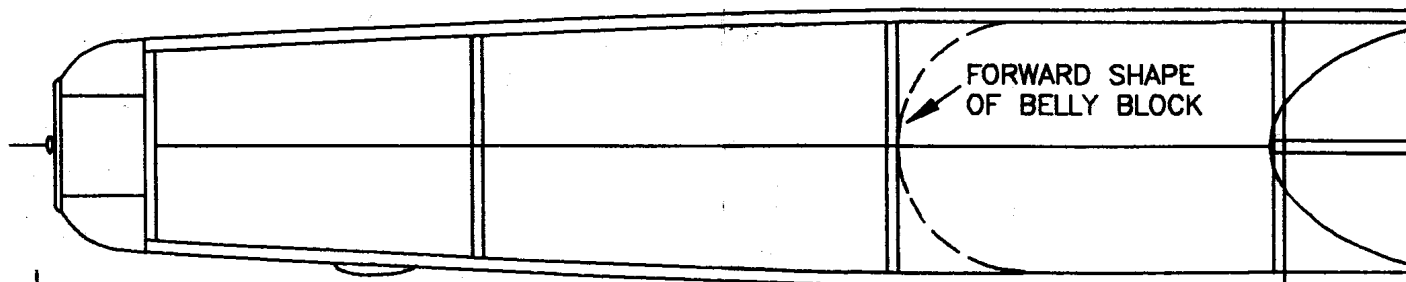

EXHAUST PORTS RIGHT SIDE ONLY. SIMULATE WITH GRAY TISSUE DISCS.

BELLY TANK CARVED OF HIGH PAINT WITH THINNED WHITE GL

DIMENSIONS ARE IN INCHES. MODEL ALL BALSA EXCE

DER - BLACK
 YELLOW
 WING - BLACK
 ELAGE, JACKRABBIT,
 RUDDER - WHITE
 LL BLACK REAR
 BLACK

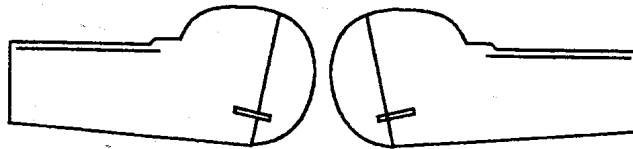

LANDING GEAR LEG COVERS OF BOND PAPER,
 COVER WITH BLACK TISSUE, ATTACH TO LOWER
 WING SURFACE WHERE INDICATED. NOTE GEAR
 RETRACTS INTO FORWARD FAIRING OF BELLY
 FUEL TANK.

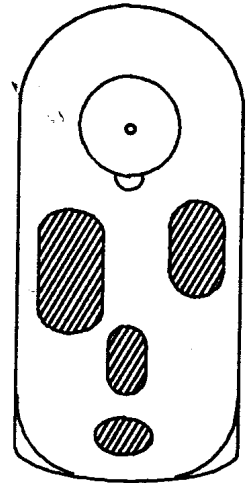
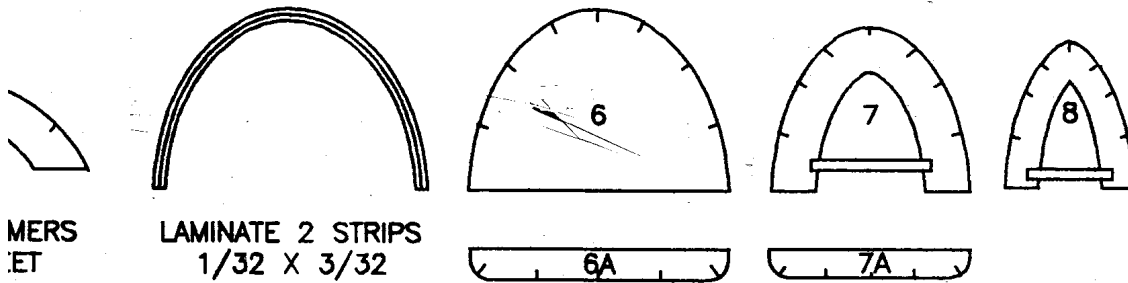

FRONT VIEW-NOSE BLOCK

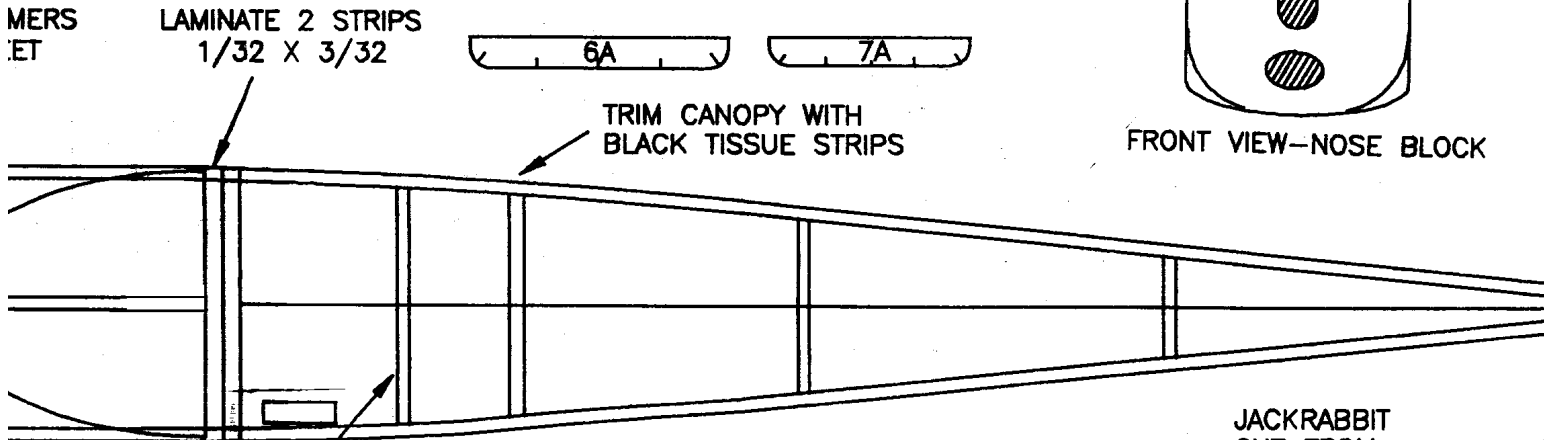

1/16 X 1/16
 LOWER FUSELAGE CROSSPIECE

TOP TURTLE DECK STRINGER
 1/16 X 1/16. ALL OTHERS
 1/16 X 1/32

JACKRABBIT
 CUT FROM
 BOND PAPER

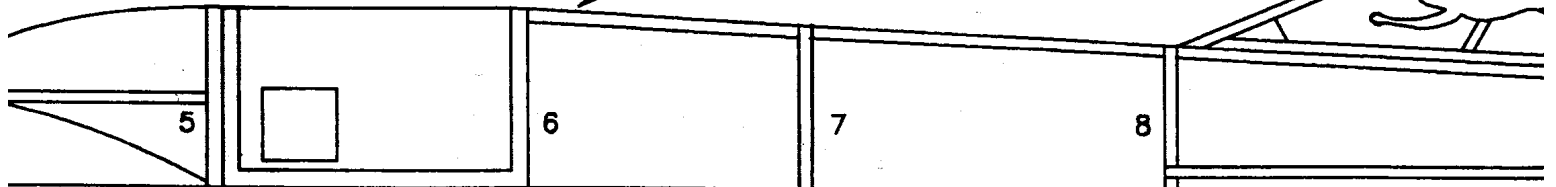

FUSELAGE LONGERONS AND
 CROSSPIECES ALL 1/16

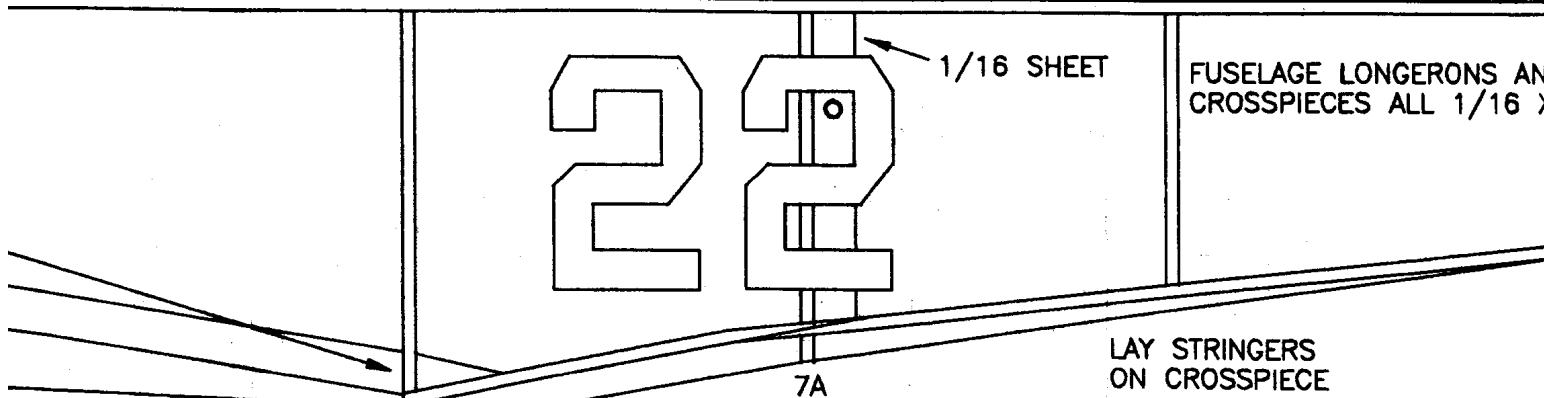

LAY STRINGERS
 ON CROSSPIECE

HIGH DENSITY FOAM
 TE GLUE, TISSUE COVER.

EXCEPT AS NOTED..

PROTOTYPE FLEW WITH 6 1/2" CUT-DOWN
 PECK 7" PROP AND ONE 24" LOOP OF
 FAI 1/8" TAN RUBBER. ~3 DEGREES
 DOWN, 2 DEGREES RIGHT THRUST.

1 1/4 INCH DIHEDRAL
UNDER EACH WINGTIP

LEADING EDGE, SPARS,
SPAR JOINERS 1/16 X 1/16

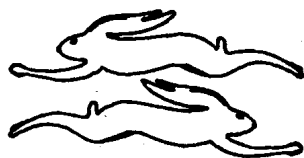

NX
264
Y

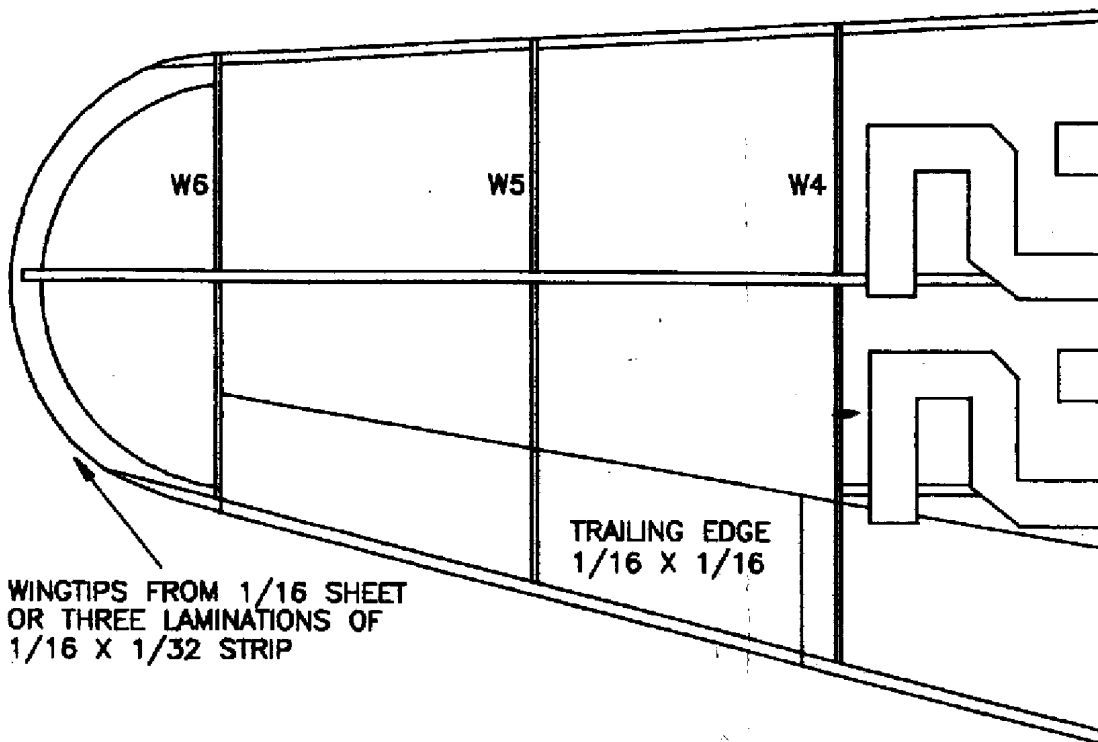

WINGTIPS FROM 1/16 SHEET
OR THREE LAMINATIONS OF
1/16 X 1/32 STRIP

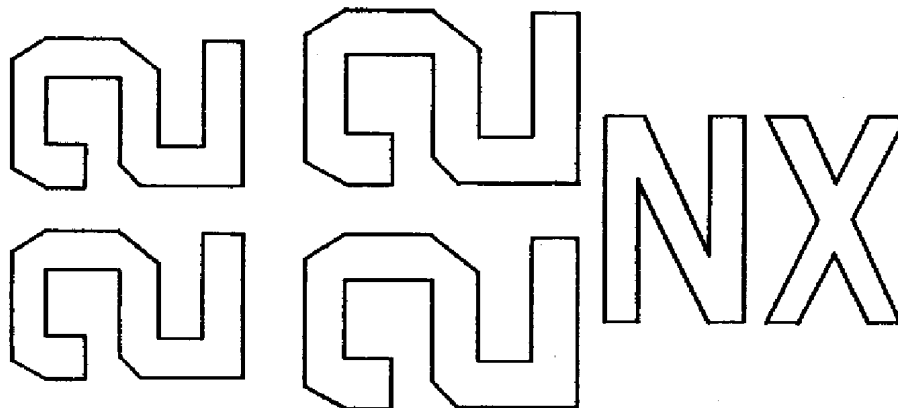
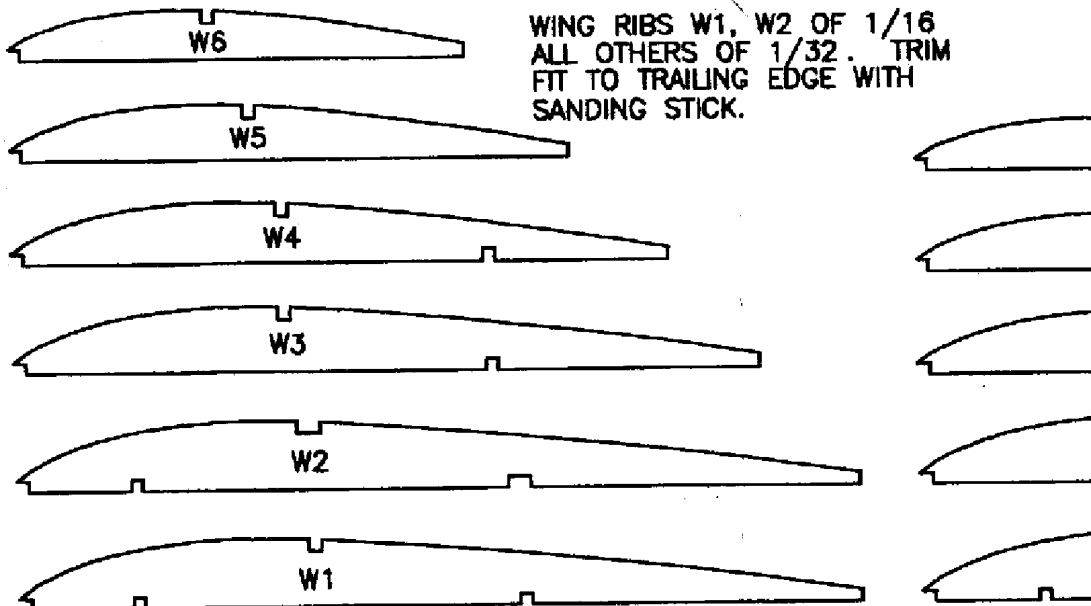
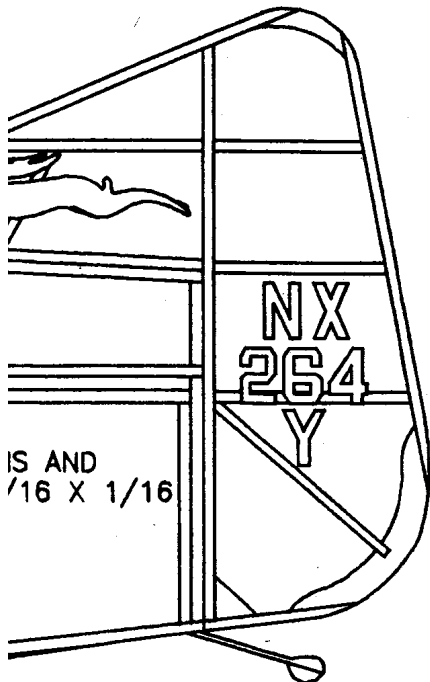
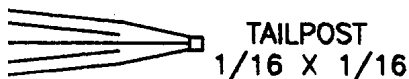

DIHEDRAL BREAK

BUILD WING CENTER SECTION FIRST
THEN BUILD AND JOIN OUTER PANELS

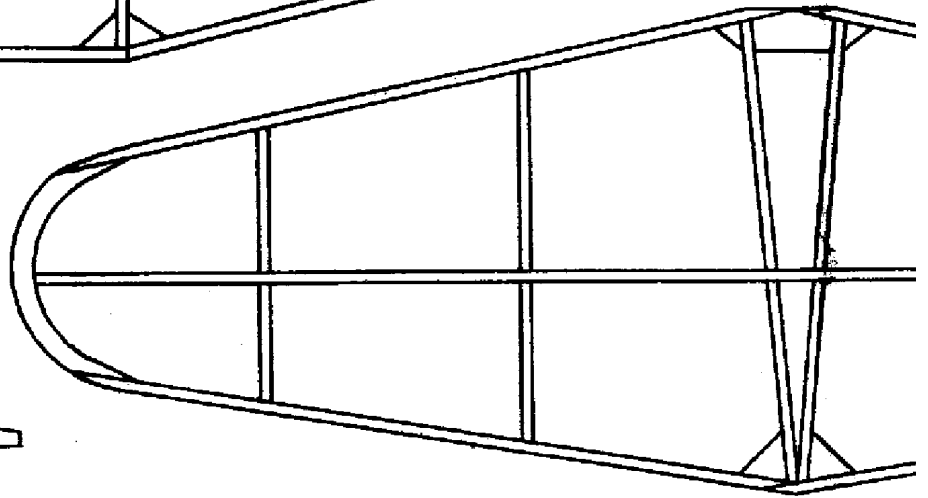
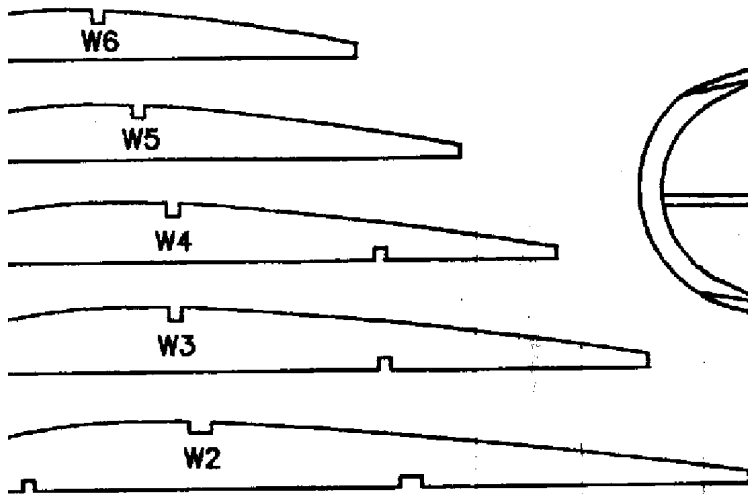
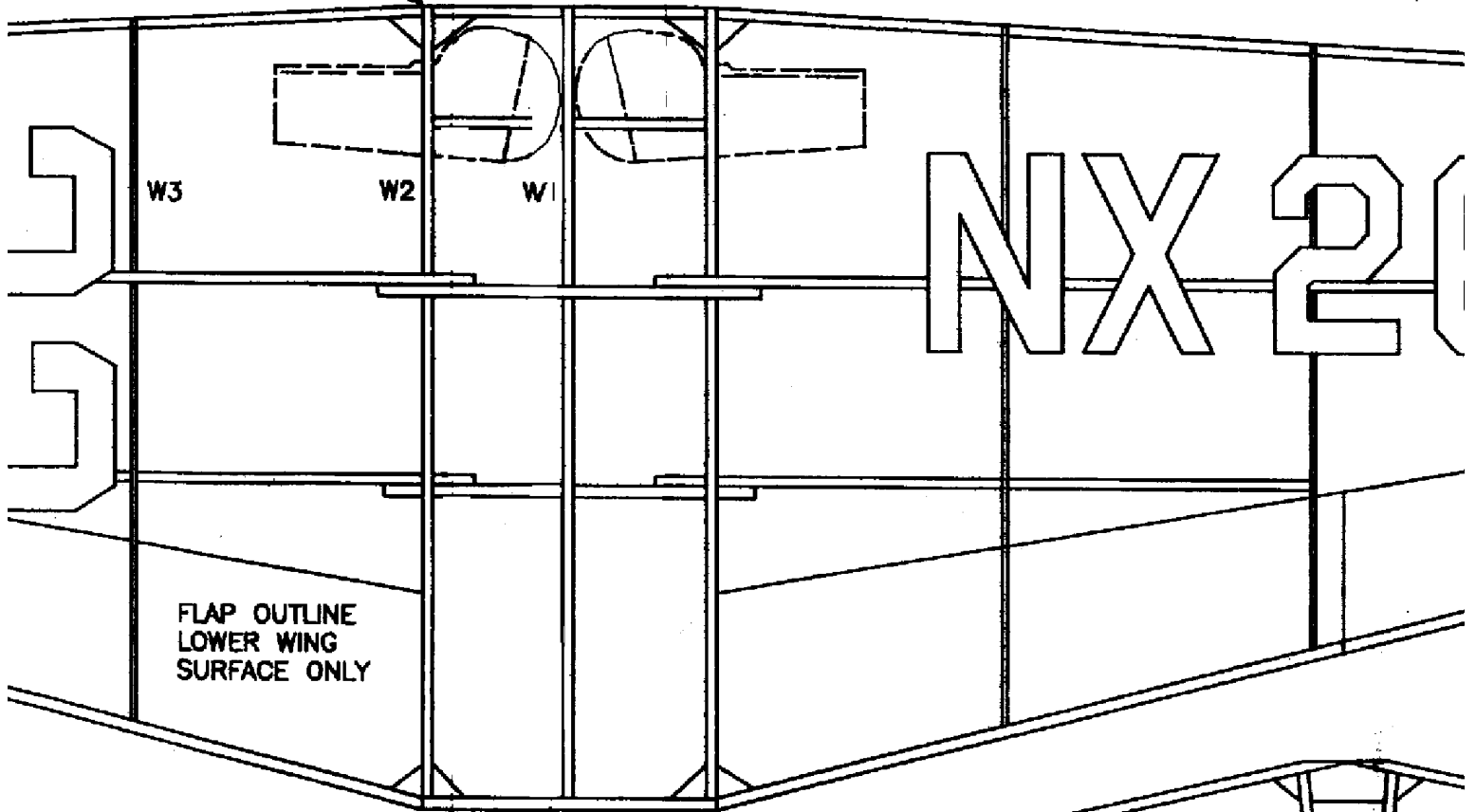

< 264Y

MARCOUX—
"JACKRA"
FORMERLY KEI
1938-39 GREVE TROPHY RACE

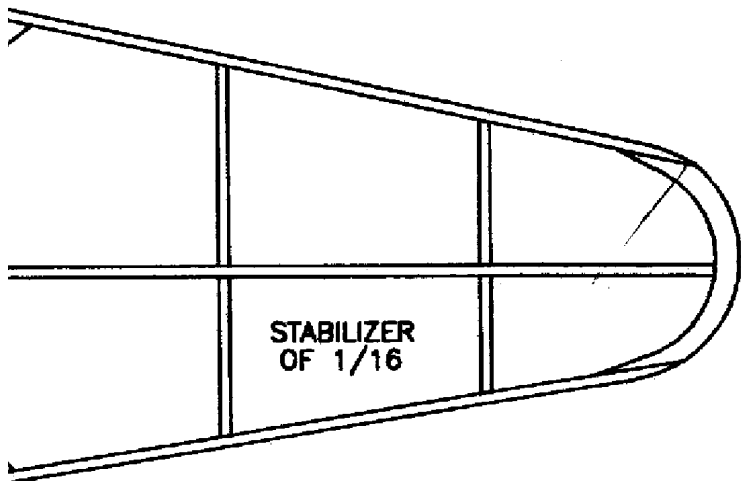
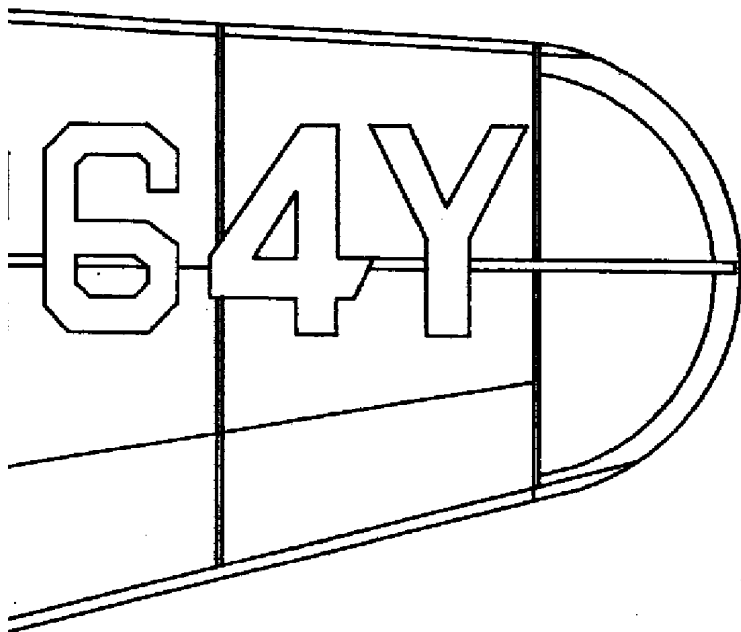

*BROMBERG
RABBIT "*

KEITH RIDER R-5

RACEPLANE

© TOM NALLEN 1993