



QuickSaver® Charge Controller for Nickel-Cadmium and Nickel-Metal Hydride Batteries

General Description

The ICS1722 is a CMOS device designed for the intelligent charge control of either nickel-cadmium (NiCd) or nickel-metal hydride (NiMH) batteries. The controller uses a pulsed-current charging technique together with voltage slope termination. The ICS1722 employs a four stage charge sequence that provides a complete recharge without overcharging. The controller has nine user-selectable charge rates and six user-selectable auxiliary modes available for customized charging systems.

The ICS1722 monitors for the presence of a battery and begins charging when a battery is installed. The ICS1722 is for applications where temperature sensing is not required by the charge controller.

Applications

Battery charging systems for:

- Portable consumer electronics
- Power tools
- Audio/video equipment
- Communications equipment

Features

- Charge termination methods include:
 - Voltage slope
 - Charge timers
- Four stage charge sequence:
 - Soft start charge
 - Fast charge
 - Topping charge
 - Maintenance charge
- Reverse-pulse charging available in all charge stages
- Nine programmable charge rates between 15 minutes (4C) and four hours (C/4)
- Continuous polling mode for battery detection
- Six auxiliary modes include:
 - Discharge-before-charge
 - Ten hour C/10 conditioning charge
 - Direct to C/40 maintenance charge
 - Charging system test provided through controller
- Adjustable open circuit (no battery) voltage reference

Block Diagram

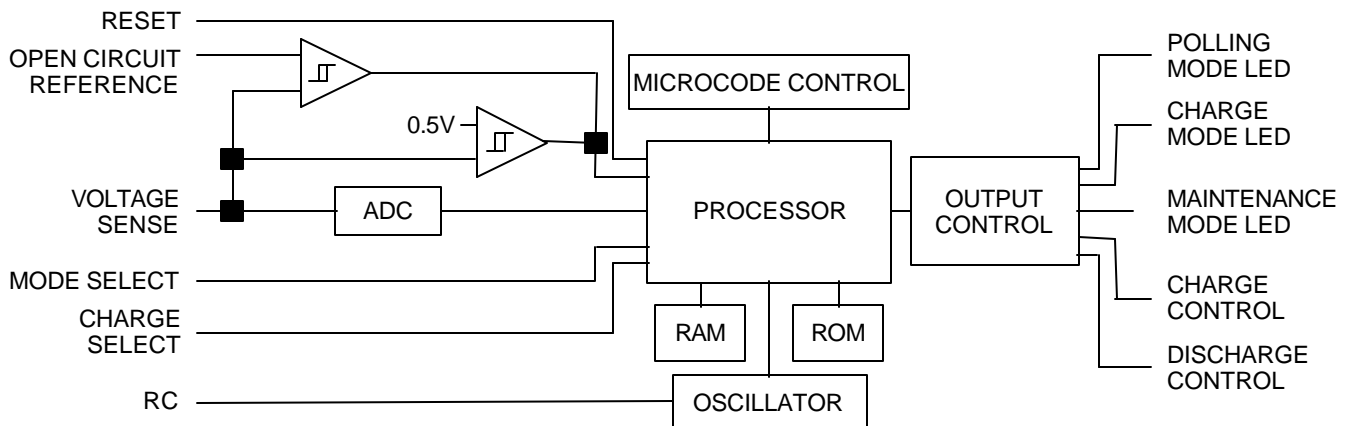

ICS1722



Pin Configuration

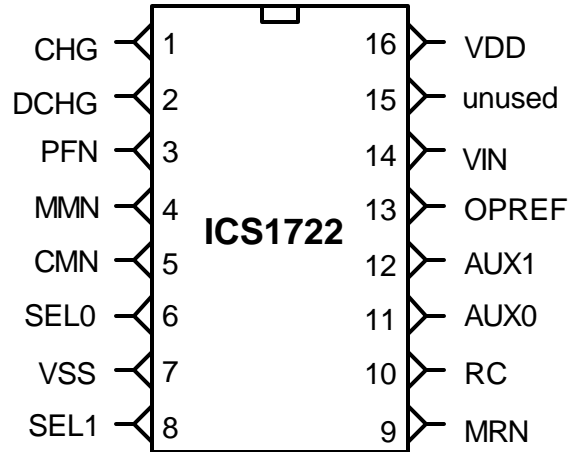

16-Pin DIP or SOIC

Pin Definitions

Pin Number	Pin Name	Type	Definition
1	CHG	OUT	Active high TTL compatible signal used to turn on an external current source to provide current to charge the battery.
2	DCHG	OUT	Active high TTL compatible signal available to turn on a discharge circuit.
3	PFN	OUT	Polling detect indicator. An active low turns on an external indicator to show the controller is polling for the presence of the battery.
4	MMN	OUT	Maintenance mode indicator. An active low turns on an external indicator showing the battery is either in the topping charge, maintenance charge or auxiliary condition mode. The indicator flashes during the auxiliary discharge mode.
5	CMN	OUT	Charge mode indicator. An active low turns on an external indicator to show the controller is either in a soft start charge or fast charge.
6	SEL0	IN	Tri-level input used with the SEL1 pin to program the device for the desired charge rate.
7	VSS		Ground.
8	SEL1	IN	Tri-level input used with the SEL0 pin to program the device for the desired charge rate.
9	MRN	IN	Master reset signal. A logic low pulse greater than 700 ms initiates a device reset.
10	RC	IN	An external resistor and capacitor sets the frequency of the internal clock.
11	AUX0	IN	Tri-level input used with the AUX1 pin to program the device for an auxiliary operating mode.
12	AUX1	IN	Tri-level input used with the AUX0 pin to program the device for an auxiliary operating mode.
13	OPREF	IN	Open circuit (no battery) voltage reference. An external resistor divider on this pin sets the open circuit voltage reference used to detect the presence of a battery.
14	VIN	IN	Battery voltage normalized to one cell with an external resistor divider.
15	unused		Ground.
16	VDD		Device supply =+5.0 VDC

Note: Pins 9 and 13 have an internal pull-up.
Pins 6,8,11,12 float to 2.3V when unconnected.



Controller Operation

Charging Stages

The charging sequence consists of four stages. The application of current is shown graphically in Figure 1. The soft start stage gradually increases current levels up to the user selected fast charge rate during the first two minutes. The soft start stage is followed by the fast charge stage, which continues until termination. After termination, a two hour C/10 topping charge is applied. The topping charge is followed by a C/40 maintenance charge.

Soft Start Charge

Some batteries may exhibit an unusual high impedance condition while accepting the initial charging current, as shown in Figure 2. Unless dealt with, this high impedance condition can cause a voltage peak at the beginning of the charge cycle that would be misinterpreted as a fully charged battery by the voltage termination methods.

The soft start charge eases batteries into the fast charge stage by gradually increasing the current to the selected fast charge rate. The gradual increase in current alleviates the voltage peak. During this stage, only positive current pulses are applied to the battery. The duty cycle of the applied current is increased to the selected fast charge rate, as shown in Figure 3, by extending the current pulse on every cycle until the pulse is about one second in duration. The initial current pulse is approximately 200ms. The CMN indicator is activated continuously during this stage

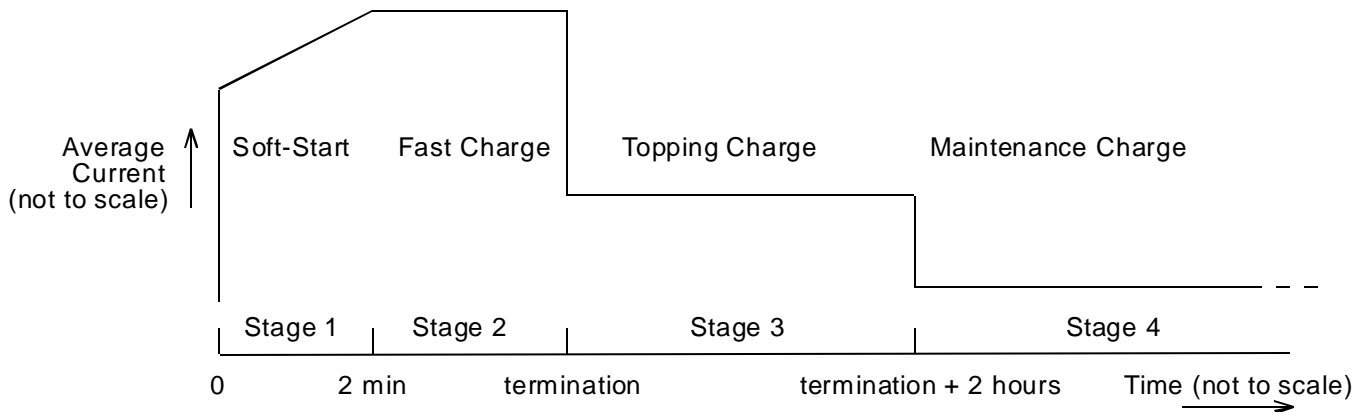

Figure 1: Graphical representation of average current levels during the four charging stages

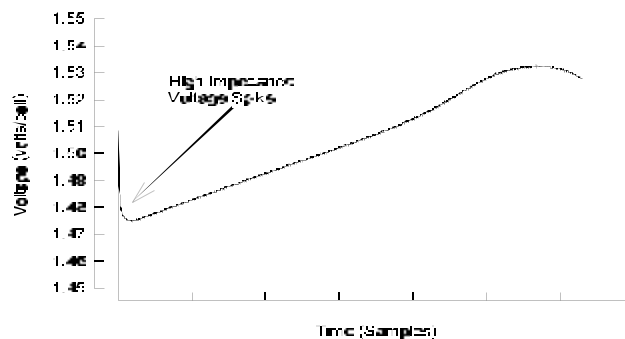

Figure 2: High impedance voltage spike at the beginning of charge

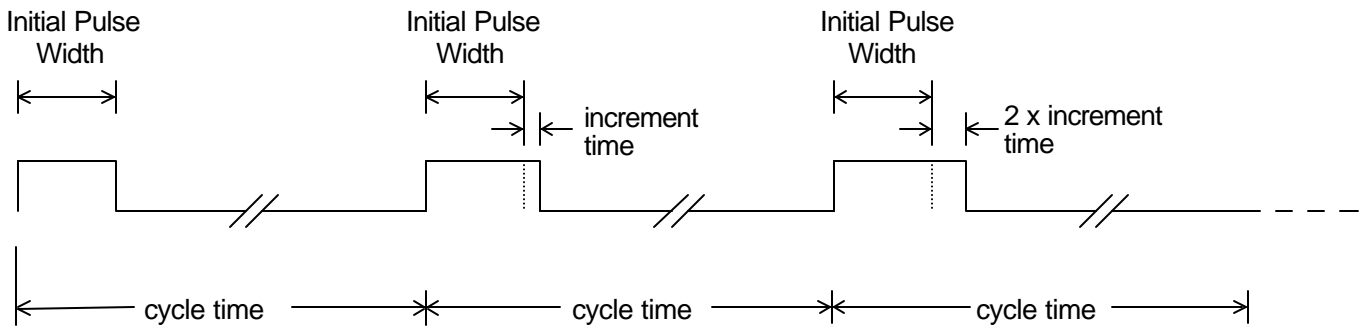

Figure 3: Cycle-to-cycle increase of the soft-start current pulse widths

Fast Charge

In the second stage, the **ICS1722** applies the charging current in a series of charge and discharge pulses. The technique consists of a positive current charging pulse followed by a high current, short duration discharge pulse. The cycle, shown with charge, discharge, rest and data acquisition periods in Figure 4, repeats every second until the batteries are fully charged.

The amplitude of the current pulse is determined by system parameters such as the current capability of the charging system, the desired charge rate, the cell capacity and the ability of that cell to accept the charge current. The **ICS1722** can be set for nine user-selectable fast charge rates from 15 minutes (4C) to four hours (C/4). Charge pulses occur approximately every second. The CMN indicator is activated continuously during this stage.

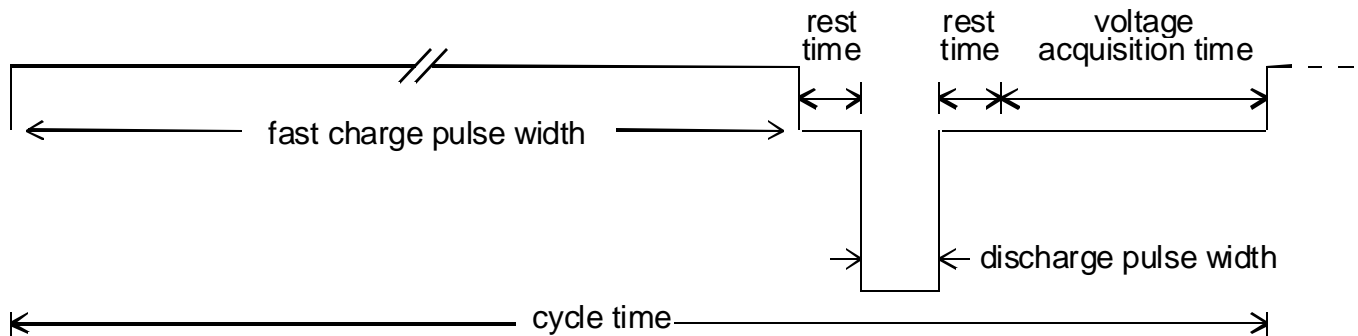

Figure 4: Charge cycle showing charge and discharge current pulses



The discharge current pulse amplitude is typically set to about 2.5 times the amplitude of the charging current based on 1.4V/cell. For example, if the charge current is 4 amps, then the discharge current is set at about 10 amps. The energy removed during the discharge pulse is a fixed ratio to the positive charge rate. The amplitude of the discharge pulse does not affect the operation of the part as described in this section.

A voltage acquisition window immediately follows a brief rest time after the discharge pulse. No charge is applied during the rest time or during the acquisition window to allow the cell chemistry to settle. Since no current is flowing, the measured cell voltage is not obscured by any internal or external IR drops or distortions caused by excess plate surface charge. The **ICS1722** makes one continuous reading of the no-load battery voltage during the entire acquisition window. The voltage that is measured during this window contains less noise and is a more accurate representation of the true state of charge of the battery.

Topping Charge

The third stage is a topping charge that applies current at a rate low enough to prevent cell heating but high enough to ensure a full charge.

The topping charge applies a C/10 charging current for two hours. The current consists of the same pulse technique used during the fast charge stage; however, the duty cycle of the pulse sequence has been extended as shown in Figure 5. Extending the time between charge pulses allows the same charging current used in the fast charge stage so that no changes to the current source are necessary. For example, the same charge pulse that occurs every second at a 2C fast charge rate will occur every 20 seconds for a topping charge rate of C/10. The MMN indicator is activated continuously during this stage.

Maintenance Charge

The maintenance charge is intended to offset the natural self-discharge of NiCd or NiMH batteries by keeping the cells primed at peak charge. After the topping charge ends, the **ICS1722** begins this charge stage by extending the duty cycle of the applied current pulses to a C/40 rate. The maintenance charge will last for as long as the battery voltage is greater than 0.5V at the VIN pin, or, if the ten hour timer mode is enabled, until the timer stops the controller.

The MMN indicator is activated continuously during this stage.

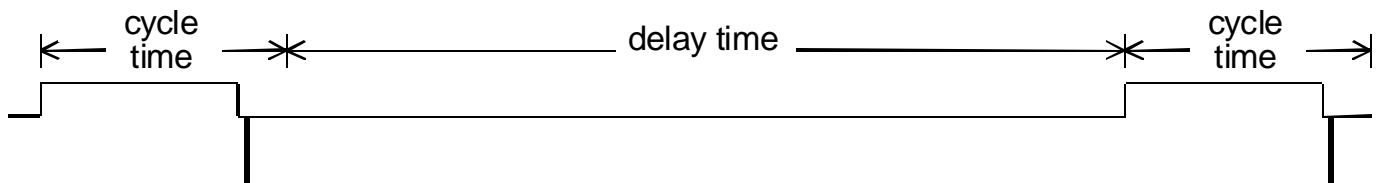

Figure 5: Representative timing diagram for topping and maintenance charge



Charge Termination Methods

Charge termination schemes include voltage slope, fast charge timer and, if desired, a ten hour timer to limit total charge time.

Voltage Slope Termination

The most distinctive point on the voltage curve of a charging battery in response to a constant current is the voltage peak that occurs as the cell approaches full charge. By mathematically calculating the first derivative of the voltage, a second curve can be generated showing the change in voltage with respect to time as shown in Figure 6. The slope will reach a maximum just before the actual peak in the cell voltage. Using the voltage slope data, the ICS1722 calculates the point of full charge and accurately terminates the applied current as the battery reaches that point. The actual termination point depends on the charging characteristics of the particular battery.

Cells that are not thoroughly conditioned or possess an unusual cell construction may not have a normal voltage profile. The ICS1722 uses an alternate method of charge termination based on a slight decrease in the voltage slope to stop charge to cells whose voltage profile is very shallow. This method looks for a flattening of the voltage slope which may indicate a shallow peak in the voltage profile. The zero slope point occurs slightly beyond the peak voltage and is shown on the voltage curve graph.

Charge Timer Termination

The controller uses a timer to limit the fast charge duration. These times are pre-programmed, and are automatically adjusted in time duration according to the charge rate selected. Fast charge timer termination is a safety backup feature to limit the duration of the fast charge stage. The fast charge timer is always enabled and cannot be disabled. See Table 3 in the section *Charge Rate Selection* for more information. To limit the total charge time to ten hours, refer to the section *Ten Hour Timer Mode* for more information.

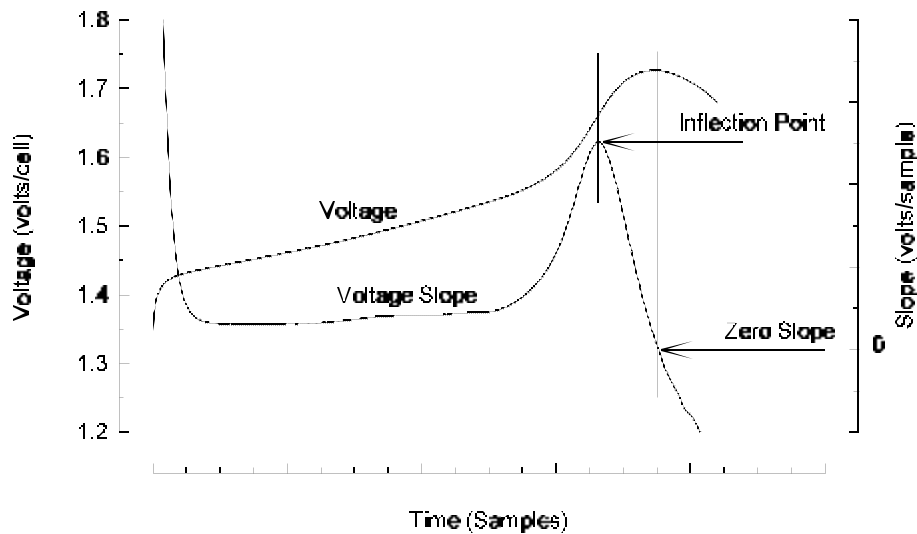

Figure 6: Voltage and slope curves showing inflection and zero slope points



Battery Detection

Upon power-up or after a master reset, excess charge from output filter capacitors at the charging system terminals is removed with a series of discharge pulses. After the discharge pulse sequence is complete, the voltage at VIN must be greater than 0.5V when a battery is present. If the voltage at the pin is less than 0.5V, the **ICS1722** assumes no battery is present, and the polling detect mode is initiated. No indicator is active during the discharge pulses.

The **ICS1722** enters the polling detect mode and applies a 100ms charge pulse. During the pulse, the **ICS1722** monitors the VIN pin to determine if the divided down terminal voltage is above OPREF. If the battery is present, the voltage will be clamped below the reference on OPREF while the current pulse is applied. If a battery is not present, the voltage at VIN will rise above the reference at OPREF.

The charge pulse will repeat until the battery is reinstalled. The polling detect indicator (PFN) is the only indicator active as long as the **ICS1722** is in the polling detect mode. Once a battery is installed, the **ICS1722** will turn off the PFN indicator and enter the soft start stage. The **ICS1722** will automatically re-enter the polling detect mode if the battery is removed.

Battery Removal

During the application of a charge pulse, the voltage at the VIN pin is compared to the voltage at the OPREF pin. If the voltage at VIN is greater than the voltage at OPREF during the application of the current pulse, then the battery is assumed to have been removed and the **ICS1722** enters the polling detect mode. If the voltage at VIN is below the voltage at OPREF, charging continues.

When in the topping charge or maintenance charge stages, a charge pulse may not occur for several seconds. During the period between charge pulses, the voltage at VIN must be greater than 0.5V if a battery is attached. If the voltage at VIN is less than 0.5V, the **ICS1722** assumes the battery has been removed, and the polling detect mode is initiated.

Auxiliary Modes of Operation

The **ICS1722** allows six alternate modes of operation to help customize the charging system for certain applications. The tri-level AUX0 and AUX1 pins are used to select the operating mode. The AUX0 and AUX1 pins default the **ICS1722** into fast charge operation. Except for the discharge-to-charge mode, another mode can only be selected by re-programming and resetting the controller.

Discharge-to-Charge Mode

The time required for discharge depends on the energy in the battery and the discharge rate. The discharge is not limited by a timer. This allows the user to set the discharge rate. The battery is drained to 1 volt/cell as read at the VIN pin under load and then the controller enters soft start at a charge rate set by the SEL0 and SEL1 inputs. The discharge load is activated by the DCHG pin which goes low for about 400ms every second. A resistor value selected for a 2.5C discharge based on 1.4V/cell results in about a 1C discharge rate.

The discharge-to-charge mode can be entered by placing the AUX0 pin high (H) and the AUX1 pin low (L) with the SEL0 and SEL1 inputs set for the desired fast charge rate. This setting initializes the discharge sequence. The **ICS1722** enters the discharge-to-charge mode at initial power-up or with a master reset. The discharge mode occurs first, to be followed by the selected fast charge mode. During discharge, the MMN indicator flashes at a one second rate, while during the soft start and fast charge stages the CMN indicator is activated continuously.

Four charge modes are available after the discharge portion is complete by changing the state of the AUX inputs during the discharge portion of this mode. The available charge modes are:
Fast Charge: Leave the AUX inputs open (Z).

- Direct Maintenance Mode: Set the AUX0 low (L) and AUX1 high (H).
- Condition Mode: Set AUX0 high (H) and AUX1 open (Z).
- Ten-Hour Timer Mode: Set AUX0 high (H) and AUX1 high (H).

If the battery is removed while in the discharge-to-charge mode, the **ICS1722** will continually reset itself until the battery is reinstalled. See *Application Information* for more information.

Discharge-Only Mode

The time required for discharge depends on the energy in the battery and the discharge rate. The discharge is not limited by a timer. This allows the user to set the discharge rate. The battery is drained to 1 volt/cell as read at the VIN pin under load. The **ICS1722** shuts down after the discharge sequence is finished and a master reset must be performed to reactivate the device. The discharge load is activated by the DCHG pin which goes low for about 400ms every second. A resistor value selected for a 2.5C discharge based on 1.4V/cell results in about a 1C discharge rate. The discharge-only mode can be entered by placing the AUX0 pin open (Z) and the AUX1 pin low (L). The **ICS1722** enters this mode at initial power-up or with a master reset. During the discharge portion, the MMN indicator flashes at a one second rate.



ICS1722

Direct Maintenance Mode

The ICS1722 can enter directly into the C/40 maintenance mode for cells that require a maintenance charge only. The direct maintenance mode is activated by setting the AUX0 pin low (L) and the AUX1 pin high (H), and resetting the device. The SEL0 and SEL1 pins must be set based on the charging current and the battery capacity. The formula

$$\frac{\text{Charging Current (Amps)}}{\text{Battery Capacity (Amp} \bullet \text{ hr)}}$$

gives the charge rate. Use Table 4 to find the correct SEL0 and SEL1 settings. The maintenance charge is applied until the battery is removed, upon which the ICS1722 will enter the polling detect mode. The ICS1722 will enter the direct maintenance mode upon initial power-up or after a master reset. The MMN indicator will be active during this mode.

Conditioning Mode

The ICS1722 can enter a conditioning mode which applies a C/10 charge for a timed 10 hour period, followed by an indefinite C/40 maintenance charge until the batteries are removed.

The conditioning mode can be entered by setting the AUX0 pin high (H) and the AUX1 pin open (Z). The SEL0 and SEL1 pins must be set based on the charging current and the battery capacity. The formula

$$\frac{\text{Charging Current (Amps)}}{\text{Battery Capacity (Amp} \bullet \text{ hr)}}$$

gives the charge rate. Use Table 3 to find the correct SEL0 and SEL1 settings. The MMN indicator will be active during the 10 hour conditioning charge and the maintenance charge that follows. The ICS1722 enters the polling detect mode if the battery is removed.

Ten Hour Timer Mode

Placing the AUX0 and AUX1 pins both high (H) enables a ten hour timer. This timer limits the total charge, including the maintenance charge, to approximately ten hours for a battery that is completely discharged before fast charge is initiated. The ten hour limit is based on the assumption that the charge terminates due to the fast charge timer as shown in Table 1.

Charging System Test

The system test mode is intended for use in applications where the charging system functionality needs to be tested. The system test sequence consists of a one second activation of the CMN, MMN and PFN indicator pins as well as the CHG and DCHG lines. The system test mode is entered by placing both the AUX0 and AUX1 pins low (L). The ICS1722 shuts down after the test sequence is finished and a master reset must be performed to reactivate the device.

Table 1: Ten Hour Timer Information

Charge Rate	Fast Charge Timer Cutoff	Maintenance Timer Cutoff (after fast charge termination)	Charge Time Limit (from reset)
4 C	0.3 hrs	9.7 hrs	10 hrs
2 C	0.6 hrs	9.4 hrs	10 hrs
1.3 C	0.9 hrs	9.1 hrs	10 hrs
1 C	1.2 hrs	8.8 hrs	10 hrs
C/1.5	1.8 hrs	8.2 hrs	10 hrs
C/2	2.4 hrs	7.6 hrs	10 hrs
C/2.5	3.5 hrs	6.5 hrs	10 hrs
C/3	4.0 hrs	6.0 hrs	10 hrs
C/4	4.6 hrs	5.4 hrs	10 hrs



Pin Descriptions

The **ICS1722** requires some external components to control the clock rate and provide an indicator display. The controller must be interfaced to an external power source that will provide the current required to charge a battery pack and, if desired, a circuit that will sink discharge current.

Output Logic Signals: CHG, DCHG Pins

The CHG and DCHG pins are active high, TTL compatible outputs. In addition to being TTL compatible, the CMOS outputs are capable of sourcing current which adds flexibility when interfacing to other circuitry. A logic high on the CHG pin indicates that the charging current supply should be activated. If applicable, a logic high on the DCHG pin indicates that the discharge circuit should be activated.

Care must be taken to control wiring resistance and inductance. The load resistor must be capable of handling this short duration high-amplitude pulse. If the auxiliary discharge-to-charge mode is selected, the power dissipation of the load resistor must be properly selected to accept the extended length of the discharge pulse.

Indicators: CMN, MMN, PFN Pins

The controller has three outputs for driving external indicators. These pins are active low. The three indicator outputs have open drains and are designed to be used with LEDs. Each output can sink over 20mA which requires the use of an external current limiting resistor. The three indicator signals denote fast charge stage, topping and maintenance stages, and the polling detect mode as shown in Table 2.

The charge mode (CMN) indicator is activated continuously during the soft start and fast charge stages. When the controller enters the topping charge stage, the output goes high and the indicator turns off.

The maintenance mode (MMN) indicator is on when the **ICS1722** is either in the topping charge, maintenance charge, direct maintenance mode, or the condition mode. The maintenance mode indicator flashes at a one second rate when the **ICS1702** is controlling the discharge portion of the discharge-to-charge or the discharge-only mode.

The polling detect (PFN) indicator is on when the **ICS1722** polls for a battery. The controller applies periodic charge pulses to detect the presence of a battery. The indicator is a warning that these charge pulses are appearing at the charging system terminals at regular intervals. When a battery is detected, the indicator is turned off.

Charge Rate Selection: SEL0, SEL1 Pins

The SEL0 and SEL1 inputs must be programmed by the user to inform the **ICS1722** of the desired charge rate. When left unconnected (open), these tri-level pins will float to about 2.3V. When a low level is required, the pin must be grounded. When a high level is required, the pin must be tied to VDD. The voltage ranges for low (L), open (Z) and high (H) are listed in Table 6, *DC Characteristics*. To program the SEL0 and SEL1 inputs, refer to the *Charge Rate List* in Table 3.

The **ICS1722** does not control the current flowing into the battery in any way other than turning it on and off. The required current for the selected charge rate must be provided by the user's power source. The external charging circuitry should provide current at the selected charge rate. For example, to charge a 1.2 ampere hour battery in 30 minutes (2C), approximately 2.4 amperes of current is required.

Table 2: Indicator Description List

PFN	MMN	CMN	Description
On			Polling mode or battery fault
	On		Maintenance or topping charge, direct maintenance or condition mode
		On	Fast charge
	Flash		Discharge portion of the discharge-to-charge or discharge-only mode
		Flash	See Applications Information
	Flash	Flash	See Applications Information
	On		Fast Charge (See Applications Information)



Table 3: Charge Rate List

SEL0	SEL1	Charge Rate	Topping Charge pulse Rate	Maintenance Charge Pulse Rate	Fast Charge Timer Duration (after reset)
L	L	4C (15 min)	one every 40 sec	one every 160 sec	21 min
L	H	2C (30 min)	one every 20 sec	one every 80 sec	39 min
L	Z	1.3C (45 min)	one every 13 sec	one every 53 sec	57 min
H	L	1C (60 min)	one every 10 sec	one every 40 sec	75 min
H	Z	C/1.5 (90 min)	one every 7 sec	one every 27 sec	110 min
H	H	C/2 (120 min)	one every 5 sec	one every 20 sec	144 min
Z	L	C/2.5 (150 min)	one every 4 sec	one every 16 sec	212 min
Z	Z	C/3 (180 min)	one every 3 sec	one every 13 sec	244 min
Z	H	C/4 (240 min)	one every 2 sec	one every 10 sec	275 min

See the section on *Controller Operation* for additional information on the topping charge and maintenance charge. See the section on *Charge Termination Methods* for additional information on the charge timer.

Mode Selection: AUX0, AUX1 Pins

The AUX0 and AUX1 inputs must be programmed by the user to inform the ICS1722 of the desired auxiliary mode. When left unconnected (open) these tri-level pins will float to about 2.3V.

When a low level is required, the pin must be grounded.

When a high level is required, the pin must be tied to V_{DD} . The voltage ranges for low (L), open (Z) and high (H) are listed in Table 6, *DC Characteristics*. To program the AUX0 and AUX1 inputs, refer to the Mode Select List in Table 4. See the section on Auxiliary Modes of Operation for additional information.

Table 4: Mode Select List

AUX0	AUX1	Mode Selected	Mode Operation
L	L	Charging System Test	Charging system test for embedded applications
L	H	Direct Maintenance	Indefinite C/40 maintenance charge
Z	Z	Fast Charge	Default
Z	L	Discharge-Only	Battery discharge to 1V/cell
H	L	Discharge-to-Charge	Battery discharge to 1V/cell followed by the selected charge mode
H	Z	Condition	Timed C/10 topping charge followed by a C/40 maintenance charge
H	H	Ten Hour Timer	Limits total charge including the maintenance charge to 10 hours



Master Reset: MRN Pin

The MRN pin is provided to re-program the controller for a new mode or charging sequence. This pin has an internal pull-up of about 75k Ω . A logic low on the MRN pin must be present for more than 700ms for a reset to occur. As long as the pin is low, the controller is held in a reset condition. A master reset is required to clear the charging system test, reset the ten hour timer, change charge rates or auxiliary modes. Upon power-up, the controller automatically resets itself.

Clock Input: RC Pin

The RC pin is used to set the frequency of the internal clock when an external 1 MHz clock is not available. An external resistor must be connected between this pin and V_{DD}. An external capacitor must be connected between this pin and ground. The frequency of the internal clock will be about 1 MHz with a 16k Ω resistor and a 100pF capacitor. All time durations noted in this document are based on a 1 MHz clock. Operating the clock at a lower frequency will proportionally change all time durations. Operating the clock at a frequency significantly lower than 1 MHz, without adjusting the charge current accordingly, will lessen the effectiveness of the fast charge timer and lower the accuracy of the controller. Operating the clock at a frequency greater than 1 MHz will also change all time durations and, without adjusting the charge current accordingly, may cause termination to occur due to the fast charge timer expiring rather than by the battery reaching full charge.

The clock may be driven by a 1 MHz external 0 to 5V pulse provided the duty cycle is between 10% and 60%. The clock input impedance is about 1k Ω .

Voltage Input: VIN Pin

The battery voltage must be normalized by an external resistor divider network to one cell. The electrochemical potential of one cell is about 1.2V. For example, if the battery consists of six cells in series, the voltage at the VIN pin must be equal to the total battery voltage divided by six. This can be accomplished with two resistors, as shown in Figure 7. To determine the correct resistor values, count the number of cells to be charged in series. Then choose either R1 or R2 and solve for the other resistor using:

$$R1 = R2 * (\# \text{ of cells} - 1) \text{ or } R2 = \frac{R1}{(\# \text{ of cells} - 1)}$$

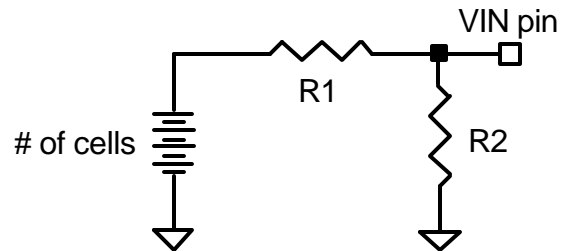

Figure 7: Resistor divider network at the VIN pin

Open Circuit Voltage Reference: OPREF Pin

The OPREF pin has an internal 75k Ω pull-up resistor to V_{DD}. OPREF requires an external pull-down resistor to establish the open circuit (no battery) voltage reference. The purpose of this voltage reference is to detect the removal of the battery from the charging system. The voltage at this pin is compared to the voltage at the VIN pin when the current source is turned on. If the voltage at VIN is greater than the voltage at OPREF, the ICS1722 assumes the battery has been removed and the ICS1722 enters the polling detect mode.

For proper operation, the voltage at OPREF must be set below the (divided down) open circuit voltage produced by the current source and above the maximum normalized battery voltage. The OPREF pin voltage must not exceed 2.3V or it will prevent the start of fast charge. If the voltage on OPREF exceeds 4V, the controller will shutdown and must be reset.

As an example, suppose that a current source has an open circuit voltage of 12V as shown in Figure 8. The maximum expected battery voltage of a six-cell pack is determined to be 9.6V. The voltage at OPREF should be set at a point between 1.6V (9.6V/6 cells=1.6V) and 2V (12V/6=2V). This is accomplished with a pull-down resistor. Refer to the VIN and OPREF resistor tables in the *Applications Information* section. From the VIN table, the divider resistors are 10k Ω and 2k Ω for R1 and R2. From the OPREF table, the pull-down resistor is 43k Ω for R3. If R3 is 43k Ω , the voltage at OPREF is 1.82V since the internal pull-up at the OPREF pin is 75k Ω .

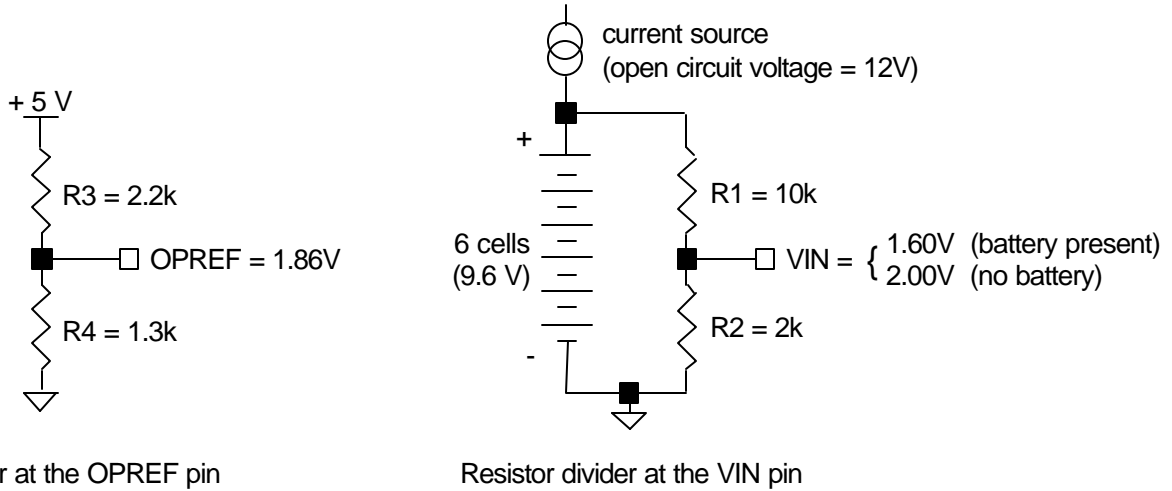

Figure 8: Open Circuit Reference Example

Power: VDD Pin

The power supply for the device must be connected to the VDD pin. The voltage should be +5 VDC and should be supplied to the part through a regulator that has good noise rejection and an adequate current rating. The controller requires up to a maximum of 11mA with VDD=5.00V.

Grounding: VSS Pin

This pin must have a direct connection to a solid ground plane.

Data Tables

Table 5: Absolute Maximum Ratings

Supply Voltage	6.5	V
Logic Input Levels	-0.5 to $V_{DD} + 0.5$	V
Ambient Operating Temperature	0 to 70	°C
Storage Temperature	-55 to 150	°C

Stresses above those listed under Absolute Maximum Ratings may cause permanent damage to the device. This is a stress rating only. Functional operation of the device at the Absolute Maximum Ratings or other conditions not consistent with the characteristics shown in this document is not recommended. Exposure to absolute maximum rating conditions for extended periods may affect product reliability.



Table 6: DC Characteristics

T_{amb}=25°C. All values given are typical at specified V_{DD}.

Parameter	Symbol	Test Conditions	MIN	TYP	MAX	UNITS
Supply Voltage	V _{DD}		4.5	5.0	5.5	V
Supply Current	I _{DD}			7.3		mA
High Level Input Voltage SEL0, SEL1, AUX0, AUX1	V _{IH}		3.6	4.1	4.5	V
Low Level Input Voltage SEL0, SEL1, AUX0, AUX1	V _{IL}		0.73	0.75	0.8	V
Open Input Voltage SEL0, SEL1, AUX0, AUX1		open		2.3		V
Low Level Input Current, pull-up MRN, OPREF	I _{IL}	V=0.4V		74		μA
High Level Source Current CHG, DCHG	I _{OH}	V= V _{DD} - 0.4V		28		mA
Low Level Sink Current CHG, DCHG	I _{OL}	V=0.4V		25		mA
Low Level Sink Current, indicator PFN, CMN, MMN	I _{OL}	V=0.4V		40		mA
Input Impedance				1.0		MΩ
Analog/Digital Converter Range			0-2.2	0-2.7	0-2.7	V
Minimum Battery Threshold				0.5		V



Table 8: Timing Characteristics

R≈16kΩ, C≈100pF

PARAMETER	SYMBOL	REFERENCE	TYP	UNITS
Clock Frequency			1.0	MHz
Reset Pulse Duration	t_{RESET}	see Figure B	700	ms
Charge Pulse Width	t_{CHG}	see Figure A	1048	ms
Discharge Pulse Width	t_{DCHG}	see Figure A	5.0	ms
Rest Time	t_R	see Figure A	4.0	ms
Data Acquisition Time	t_{DA}	see Figure A	16.4	ms
Cycle Time	t_{CYCLE}	see Figure A	1077	ms
Capacitor Discharge Pulse Width			5.0	ms
Capacitor Discharge Pulse Period			100	ms
Polling Detect Pulse Width			100	ms
Polling Detect Pulse Period			624	ms
Soft Start Initial Pulse Width			200	ms
Soft Start Incremental Pulse Width			7.0	ms
Discharge Mode Pulse Width			400	ms
Discharge Mode Pulse Period			1050	ms
RESET to SEL Dynamic Reprogram Period	t_{RSA}	see Figure B	1160	ms

Timing Diagrams

Figure A:

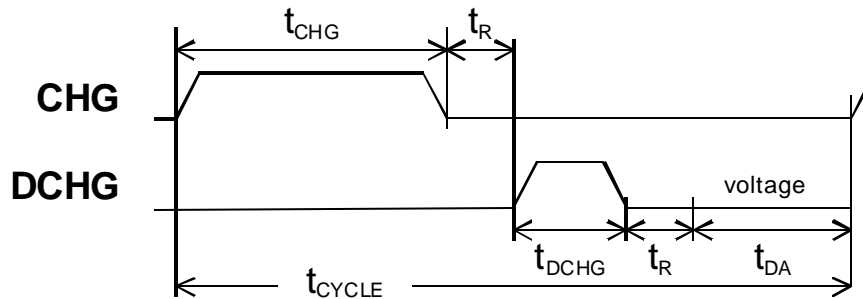
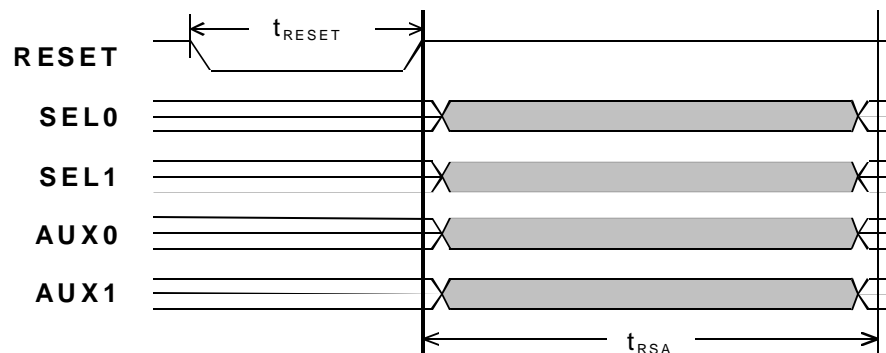

Figure B:





Applications Information

To ensure proper operation of the **ICS1722**, external components must be properly selected. The external current source used must meet several important criteria to ensure optimal performance of the charging system. The charging current should be constant when using voltage slope termination.

VIN and OPREF Divider Resistors

Figure 9 shows a typical application using the **ICS1722**. R1 through R3 must be carefully selected to ensure that battery detection and voltage termination methods operate properly.

R1 and R2 are selected to scale the battery voltage down to the voltage of one cell. The following table shows some typical values. Additional information is available in the *Voltage Input* section.

Cells	R1	R2
1	Short	Open
2	2.0k	2.0k
3	2.0k	1.0k
4	3.0k	1.0k
5	12k	3.0k
6	10k	2.0k
7	12k	2.0k
8	9.1k	1.3k

The current source should prevent ripple voltage from appearing on the battery. The effects of ripple on the battery voltage may interfere with proper operation.

R3 is used to set the open circuit (no battery) reference voltage on the OPREF pin. The function of this pin is discussed in the *Open Circuit Reference* section.

V _{OPREF}	R3
1.82 V	43k
1.93 V	47k
2.02 V	51k
2.14 V	56k

With the batteries removed, the current source must be capable of raising the voltage at the VIN pin above the voltage at the OPREF pin to ensure proper polling. With the batteries in-stalled, the current source overshoot characteristics when turned on and off must not cause the voltage at the VIN pin to exceed the voltage at the OPREF pin. If the voltage at OPREF exceeds the voltage at VIN when a charge pulse is applied or removed, the polling feature will be activated.

PC Board Design Considerations

It is very important that care be taken to minimize noise coupling and ground bounce. In addition, wires and connectors can add significant resistance and inductance to the charge and discharge circuits.

When designing the printed circuit board, make sure ground and power traces are wide and bypass capacitors are used right at the controller. Use separate grounds for the signal, charge and discharge circuits. Separate ground planes on the component side of the PC board are recommended. Be sure to connect these grounds together at the negative lead of the battery only. For the discharge circuit, keep the physical separation between power and return (ground) to a minimum to minimize field radiation effects. This precaution is also applicable to the constant current source, particularly if it is a switch mode type. Keep the **ICS1722** and the constant current source control circuits outside the power and return loop described above. These precautions will prevent high circulating currents and coupled noise from disturbing normal operation.

Using the Voltage Slope Termination Method

In general, the voltage slope termination method works best for equipment where the battery is fast charged with the equipment off or the battery is removed from the equipment for fast charge.



The voltage slope termination method used by the **ICS1722** requires a nearly constant current flow into the battery during fast charge. Charging the battery in equipment that draws a known constant current while the battery is charging should have this current draw added to the fast charge current. Using the **ICS1722** for charging the batteries in equipment that randomly or periodically requires moderate current from the battery during fast charge needs evaluation. Equipment that randomly or periodically requires high current from the battery during fast charge may cause a voltage inflection that results in termination before full charge. A voltage inflection can occur due to the charge current decreasing or fluctuating as the load changes rather than by the battery reaching full charge. The voltage slope method will terminate charge based on voltage inflections that are characteristic of a fully charged battery. The

ICS1702 and ICS1712 charge controllers have temperature termination methods for equipment that randomly or periodically draws significant current from the battery during fast charge.

Charging sources that produce decreasing current as fast charge progresses may also cause a voltage inflection that may result in termination before full charge. For example, if the charge current is supplied through a resistor or if the charging source is a constant current type that has insufficient input voltage, the current will decrease and may cause a termination before full charge. Other current source abnormalities that may cause a voltage inflection that is characteristic of a fully charged battery are inadequate ripple and noise attenuation capability or charge current decreasing due to thermal drift. Charging sources that have any of the above characteristics need evaluation to assess their suitability for the application if the use of the voltage slope termination is desired.

The controller soft start stage, built-in noise filtering, and fast charge timer operate optimally when the constant current source charges the battery at the rate selected. If the actual charge current is significantly less than the rate selected, the conditioning effect of the soft start stage and the controller noise immunity are lessened. Also, the fast charge timer may cause termination based on time duration rather than by the battery reaching full charge due to inadequate charge current.

Charging System Status by Indicator

The *Indicator Description List* in Table 2 contains displays that are caused by charging system abnormalities. When the CMN indicator is flashing with no other indicator active, there is voltage present at the battery terminals with the current source off and no battery. Check the current source and ensure that it produces no more than the equivalent of 350mV/cell when turned off with no battery. If the VIN divider resistors were not properly selected, an open circuit voltage that is actually less than the equivalent of 350mV/cell with the charger off and no battery will not divide down this open circuit voltage properly and produce the CMN flash indication. Check the VIN divider and ensure that it properly normalizes the battery voltage to the electrochemical potential of about 1.2V cell. If the CMN flash indication occurs with the battery installed, then the constant current source is producing more than the equivalent of 350mV/cell when off and there is an open connection between the charger terminals and the battery. Check wires, connections, battery terminals, and the battery itself for an open circuit condition.

If the MMN and CMN indicators are alternately flashing, the likely cause is no battery with the **ICS1722** programmed in the discharge-to-charge auxiliary mode. If the battery is present, check wires, connectors, battery terminals, and the battery itself for an open circuit condition.

If the MMN indicator is active at the initiation of fast charge, check the external pull-down resistor from OPREF to ground. A voltage at OPREF that exceeds 2.3V will prevent the start of fast charge.



ICS1722

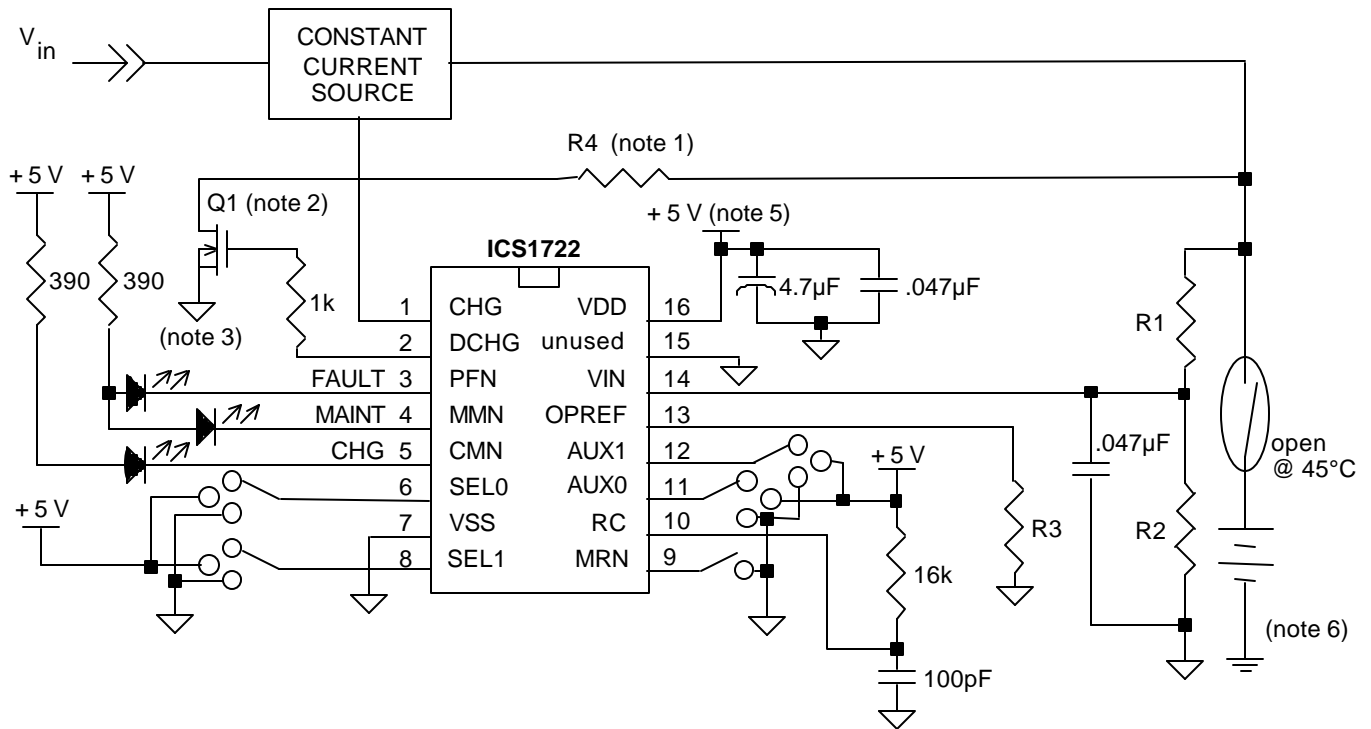

Notes:

- 1) Value of R4 determined by discharge current and capacity of battery pack.
- 2) Discharge FET is logic-level compatible in this application.
- 3) DC return of discharge FET must be connected close to negative battery terminal.
- 4) Regulated supply
- 5) Power ground; others are signal ground. Connect signal ground to power ground at negative battery terminal only.

Figure 9: Functional Diagram



ICS1722

Package Information

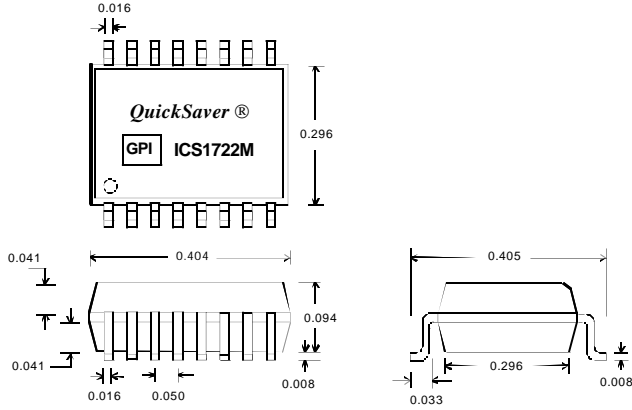

All package dimensions are in inches.
16-Pin SOIC Package (300 mil)

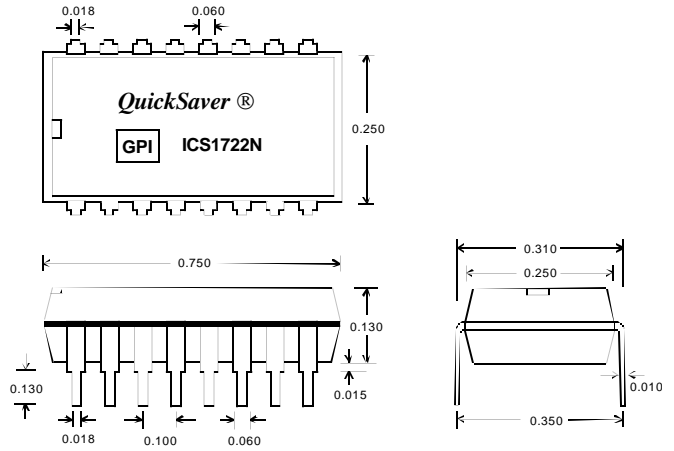

All package dimensions are in inches.
16-Pin DIP package (300 mil)

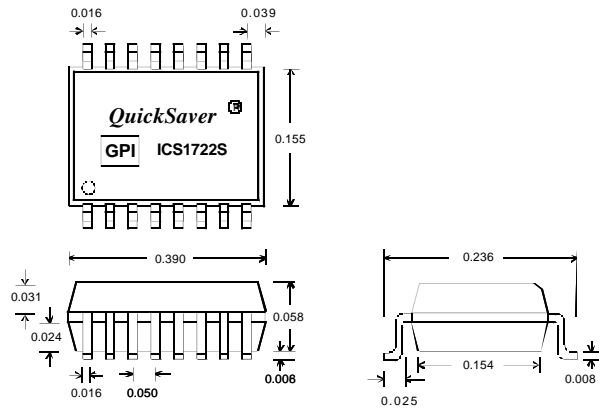

All package dimensions are in inches.
16-Pin SOIC Package (150 mil)

Ordering Information:

ICS1722M, ICS1722MT,
 ICS1722S, ICS1722ST, ICS1722N

Example:

ICS 1712 ST

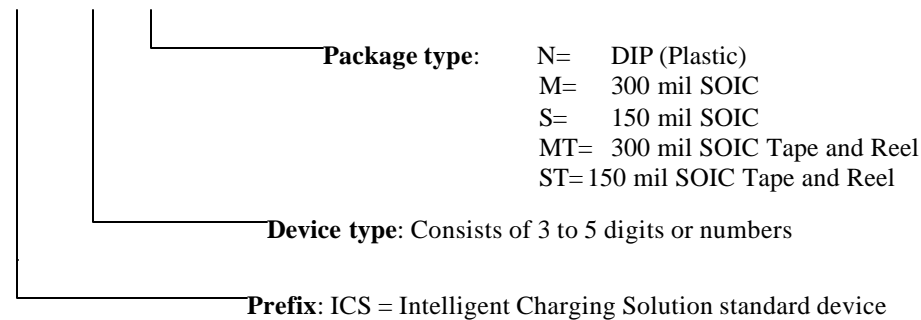



IMPORTANT NOTICE

Galaxy Power Incorporated makes no claim about the capability of any particular battery (NiCd or NiMH) to accept a fast charge. GPI strongly recommends that the battery manufacturer be consulted before fast charging. GPI shall be held harmless for any misapplication of this device such as: exceeding the rated specifications of the battery manufacturer; charging batteries other than nickel-cadmium or nickel-metal hydride type; personal or product damage caused by the charging device, circuit, or system itself; unsafe use, application, and/or manufacture of a charging system using this device.

GPI reserves the right to make changes in the device data identified in this publication without further notice. GPI advises its customers to obtain the latest version of all device data to verify that any information being relied upon by the customer is current and accurate.

GPI does not assume any liability arising out of or associated with the application or use of any product or integrated circuit or component described herein. GPI does not convey any license under its patent rights or the patent rights of others described herein. In the absence of a written or prior stated agreement to the contrary, the terms and conditions stated on the back of the GPI order acknowledgment obtain.

GPI makes no warranty of any kind with regard to this material, including, but not limited to, the implied warranties of merchantability and fitness for a particular purpose.

GPI products are not designed, intended, or authorized for use as components in systems intended for surgical implant into the body, or other applications intended to support or sustain life, or for any nuclear facility application, or for any other application in which the failure of the GPI product(s) could create a situation where personal injury or death may occur. GPI will not knowingly sell its products for use in such applications, and the buyer shall indemnify and hold harmless GPI and its officers, employees, subsidiaries, affiliates, representatives and distributors against all claims, costs, damages, expenses, tort and attorney fees arising out of directly or indirectly, any claim of personal injury or death associated with such unintended or unauthorized use, even if such claim alleges that GPI was negligent regarding the design or manufacture of the part.

COPYRIGHT © 1998 Galaxy Power Incorporated



ICS1722

NOTES





ICS1722

NOTES



NOTES

ICS1722

ICS1722



GPI Sales Offices

Headquarters

Galaxy Power, Inc.

PO Box 890

2500 Eisenhower Avenue

Valley Forge, PA 19482-0890

Phone: 1-610-676-0188

FAX: 1-610-676-0189

Internet: www.galaxypower.com

January 20, 1999

GPI Sales Representative
